

SHIJIAZHUANG MAXWELL TECHNOLOGY CO., LTD

MXR100040 Charging Module

User Manual

Version V1.2

Date: 2021.11.15



Copyright © Shijiazhuang Maxwell Technology Co., Ltd. All rights reserved.
The information in this document is subject to change without notice.

Shijiazhuang Maxwell Technology Co., Ltd.

Postcode: 050000

Website: www.maxwellpower.cn

Customer service hotline: +86-311-81659598

Index

1 MXR100040 Charging Module Overview.....	3
1.1 Specifications.....	3
1.2 Function Details.....	5
2 Structure and Installation.....	8
2.1 Structure.....	8
2.2 Dimensions.....	11
2.3 Installation.....	12
2.4 Use.....	12
3 Maintenance Guide.....	14
3.1 Troubleshooting.....	14
3.2 Replace Charging Module.....	15
Appendix I Identification Chart of Toxic and Harmful Substance.....	16

1 MXR100040 Charging Module Overview

1.1 Specifications

Table1-1 charging module Parameters

Item	Specifications
Basic Specifications	
Dimensions	85mm(H)×360mm(W)×459mm(D)
Weight	≤20kg
Efficiency(full load)	>95.5%
Standby Power Consumption	13W+/-0.5W
Cooling Mode	Forced air cooling
Communications Bus Protocol	CAN bus
No. of Parallel Modules	≤60pcs
Indicator	Green: normal operation Yellow: alarm Red: fault
Input Characteristics	
Input Voltage	285Vac~475Vac, three phase + protective earth
Input Current	< 80A
Grid Frequency	45Hz~65Hz
Power Factor	≥0.95 (8KW≤Output power ≤20KW); ≥0.98 (20KW≤Output power≤40KW)
ITHD	≤5% (20KW≤Output power≤40KW)
Output Characteristic	
Voltage Range	100Vdc~1000Vdc
Current Range	0A~133.3A (continuously adjustable)
Rated Current	40A
Steady voltage	≤±0.5% (voltage stabilization status, input voltage 323Vac~456Vac, output voltage 200Vdc~1000Vdc, output current 0~rated current).
Current precision	≤±1% (voltage stabilization status, input voltage 323Vac~456Vac, output voltage 200Vdc~1000Vdc, output current 20% rated current~100% rated current).
Current Sharing Imbalance	≤±3%
Ripple Voltage Peak Value Coefficient	≤1% (voltage stabilization status, input voltage 323Vac~456Vac, output voltage 200Vdc~1000Vdc, output current 0~rated current).
Environmental Specifications	
Operating Temperature	-40°C~+75°C, output derating above 55°C
Storage Temperature	-40°C~+75°C
Relative Humidity	≤95%RH, non-condensing

Altitude	No derating below 2000m, When the altitude is above 2000 m, the operating temperature decreases by 1°C for each additional 100 m.		
MTBF	>500,000 hours		
EMC			
Surge	Line-line:±2kV, Line-ground: ±4kV, Level :4 Reference standard : IEC61851-21-2 : 2018		
EFT	±4kV	Level : 4	Reference standard : IEC61851-21-2 : 2018
ESD	±6kV/±8kV	Level : 3	Reference standard : IEC61851-21-2 : 2018
PQF	Voltage dips meets IEC61851-21-2:2018; Short interruptions immunity meets IEC61851-21-2:2018; Reference standard : IEC61851-21-2 : 2018.		
PFMF	100A/m	Level: 5	Reference standard : IEC61851-21-2 : 2018
RF-EMS	10V/m	Level: 3	Reference standard : IEC61851-21-2 : 2018
Conducted Susceptibility	Meets requirements @0.15~80MHz		Reference standard : IEC61851-21-2 : 2018
Harmonic Current Emission	Meets IEC61851-21-2:2018 requirements		Reference standard : IEC61851-21-2 : 2018
Voltage Fluctuation and Flicker	Meets IEC61851-21-2:2018 requirements		Reference standard : IEC61851-21-2 : 2018
Conducted Emission	Class A, meets IEC61851-21-2:2018 requirements Reference standard: IEC61851-21-2 : 2018		
Radiation Emission	Class A, meets IEC61851-21-2:2018 requirements Reference standard: IEC61851-21-2 : 2018		
Others			
Emergency Stop Protection	External input 12V, low level operation, high level shutdown (high level range: 9V ~ 15V)		
Safety Requirements	Meets general specifications for electric vehicle off-board DC charger, IEC61851-23:2014		
Startup Time	Output startup time 3~8s		
Insulation Resistance	DC/AC to enclosure, DC to AC ≥10MΩ		
Dielectric Strength	AC input connector to CAN, 4242Vdc voltage, 1min, no breakdown or flashover, steady state leakage current <10 mA; AC input connector to Enclosure, 2121Vdc voltage, 1min, no breakdown or flashover, steady state leakage current <10 mA; AC input connector to DC output connector, 2121V DC voltage, 1min, no breakdown or flashover, steady state leakage current <10 mA; DC output connector to Enclosure, 2121V DC voltage, 1min, no breakdown or flashover, steady state leakage current <10 mA; DC output connector to CAN, 4242V DC voltage, 1min, no breakdown or flashover, steady state leakage current <10 mA; CAN to Enclosure, 707V DC voltage, 1min, no breakdown or flashover, steady state leakage current <10 mA;		
ROHS	R5		

1.2 Function Details

1.2.1 Hot-plugging

Hot-plugging charging modules, easy installation and maintenance.

1.2.2 Current sharing

Auto current sharing between modules, current imbalance less than 3%.

1.2.3 AC input Power limiting

The relationship between output power and input voltage is shown in Chart 1-1. When input voltage is between 323Vac~475Vac (hysteresis less than 15V), module can output maximum power.

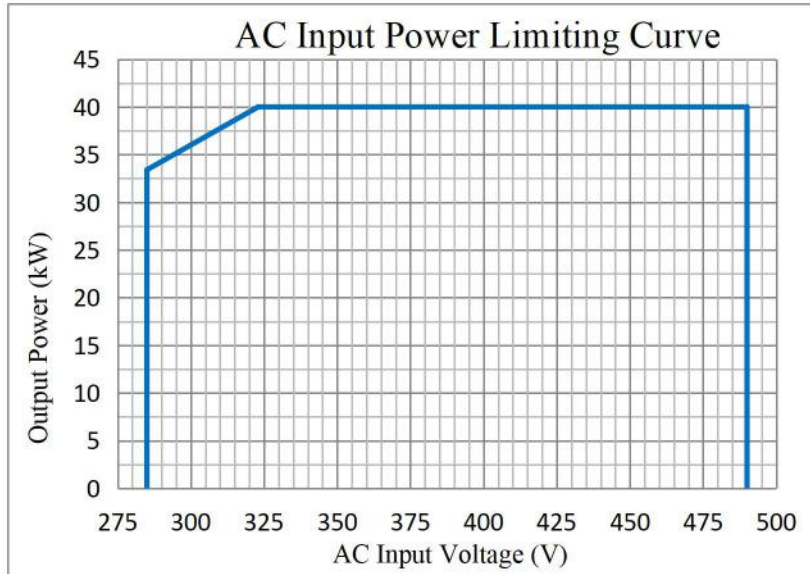

Chart 1-1 AC Input Power Limiting Curve

1.2.4 Output constant power control

MXR100040 is at rated input voltage, allowed output power is 40kw, relationship between output voltage and output current is shown in Chart 1-2.

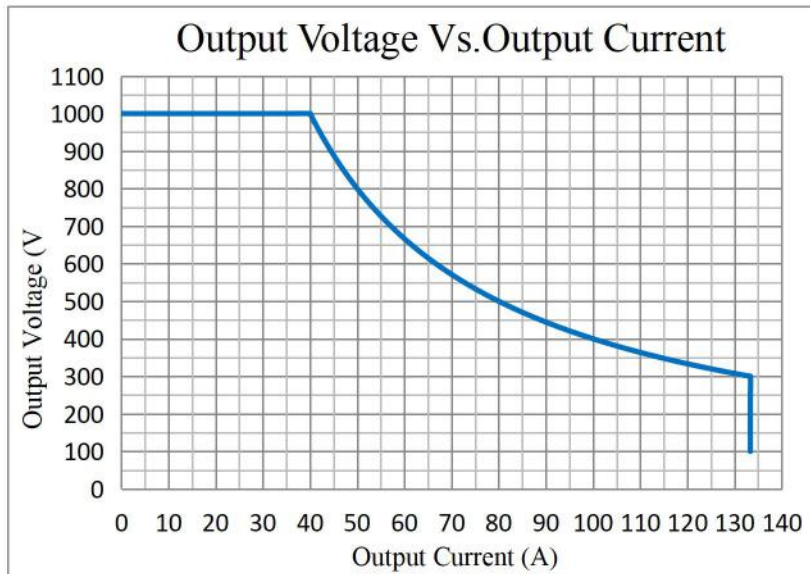

Chart 1-2 Output Voltage vs. Output Current

1.2.5 Temperature derating

This module provides full power output at ambient temperature below 55 °C;

This module is operated by derating at ambient temperature above 55 °C. It is a piecewise linear limit power;

The ambient temperature is 75 °C and the output power of the module is 10kW;

The output power of this module reduces till 0 at ambient temperature of 75 °C.

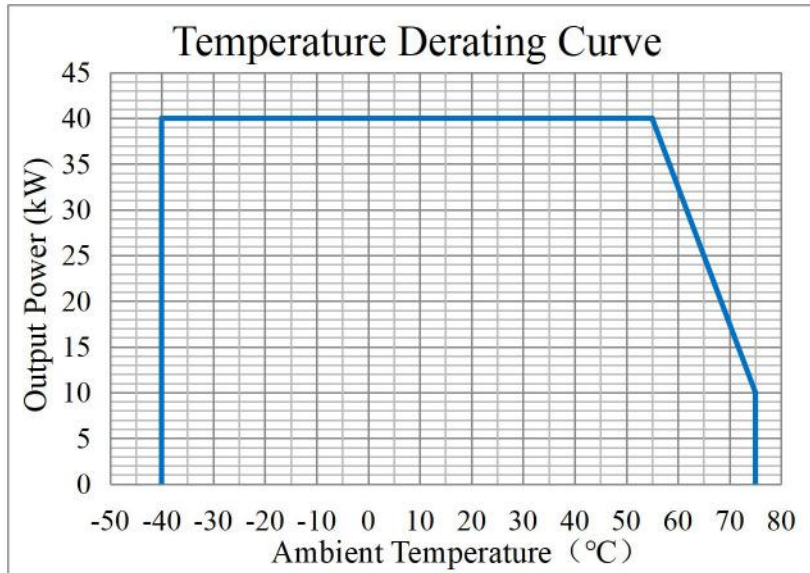

Chart 1-3 Temperature Derating Curve

1.2.6 Output current configuration

Through external monitor module, current of module can be configured continuously between 0A to 133.3A.

1.2.7 Output voltage adjustment

Through external monitor module, output voltage of modules can be adjusted continuously from 100Vdc to 1000Vdc, minimum adjustable pace is 0.1Vdc.

1.2.8 Input over/under voltage protection

When input voltage is less than 270Vac or greater than 490Vac, protection alarm indicator goes on, the module will stop working, no output.

When overvoltage or undervoltage alarm occurs, module will report it to the monitor; LED digital tube shows fault code E03.

1.2.9 Output overvoltage protection

The fixed overvoltage protection point for MXR100040 charging module is 1025 Vdc, and the fixed undervoltage protection point is 95Vdc. The software overvoltage protection point can be set within 200 Vdc~1025 Vdc by monitoring module and the factory default is 1025 Vdc.

The red indicator goes on, LED digital tube shows fault code E06, the module need to be reset by removing from the system to start.

The yellow indicator of overvoltage protection rear panel turns on, LED digital tube will display the fault code E01, the output voltage is greater than 95Vdc, the module clears the alarm and resumes the startup.

1.2.10 Over temperature protection

The overtemperature protection point for ambient temperature is 75 °C. The module shuts down automatically at ambient temperature above 75 °C, the yellow indicator on the panel turns

on and LED digital tube displays the fault code E02.

1.2.11 Internal bus fault protection

If the internal bus voltage exceeds the overvoltage/undervoltage protection point or encounters imbalance, the module will automatically shut down, have no output and the yellow indicator on the panel will turn on.

1.2.12 Short circuit protection

The module will shut down when a short circuit situation occurs, red indicator goes on and module will report "module failure" to the monitor. LED digital tube shows fault code E05

1.2.13 Background communication failure

If the communication of MXR100040 module is interrupted for more than 10s, the module will provide shutdown protection, have no voltage output, the yellow indicator on the panel will turn on. After the communication of the module is recovered, the yellow indicator on the panel off, and the module will be recovered to work in default state.

2 Structure and Installation

2.1 Structure

1) Front Panel

Indicators, LED digital tubes and buttons on the front panel of the charging module are shown in Figure 2-1 and 2-2.



Figure 2-1 Front Panel

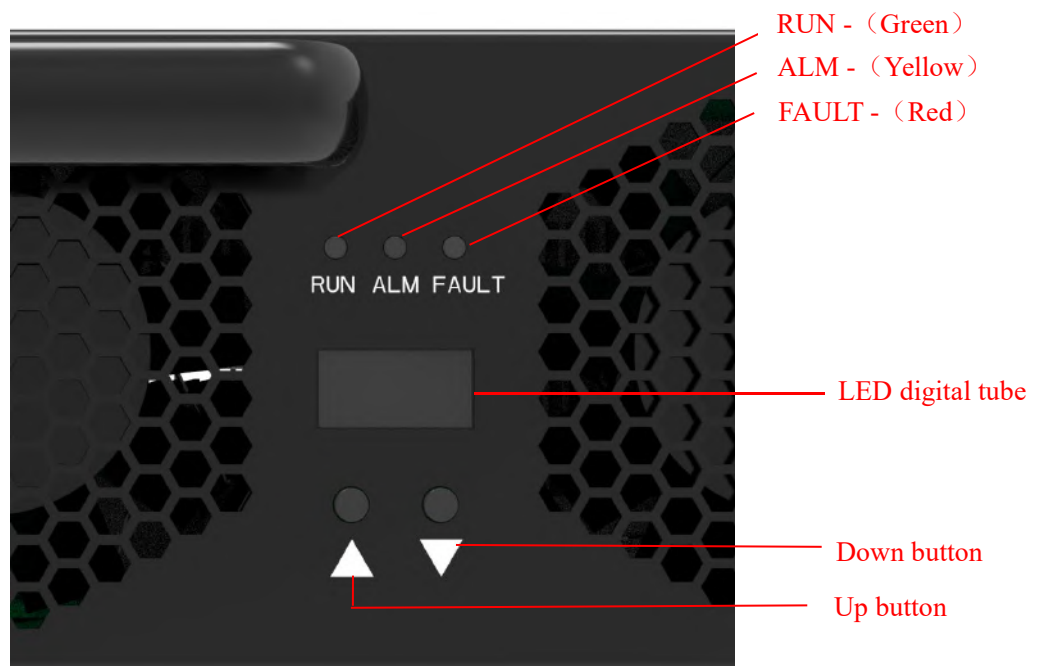

Figure 2-2 Front Panel Information

Front panel has three indicators, Indicator descriptions see Table 2-1.

Table 2-1 Indicator Descriptions

Indicator	Normal State	Abnormal State	Description
Run (green)	Steady On	Off	Charger has no input power
ALM(yellow)	Off	Steady on	AC input fault, over temperature, bus voltage fault, output under voltage, severe current imbalance
Fault (red)	Off	Steady on	Output over voltage, output short circuit, internal address confliction

LED digital tube can display module output voltage, output current, address, group number, fault code, module version, packet mode, operation mode and on-off status information.

Module has two button, up button (▲) and down button (▼). The module information can be viewed by pressing the button. Press (▲) or (▼) to display in sequence as shown in Figure 2-3, the first page is the output voltage by default.

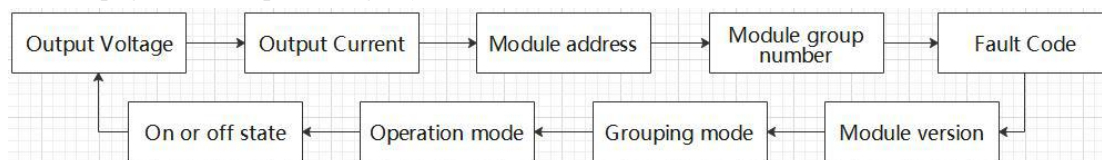

Figure 2-3 Module information display sequence

Through button, it can set module parameters: module address and module group number. The group number can only be changed by button when the module is in standby mode and the group mode is dynamic. The steps of setting module parameters are as follows:

1. Press (▲) or (▼) to switch the display to the information interface.
2. Press (▲) or (▼) for about 2.5 seconds, then release, and the display will blinking.
3. Press (▲) or (▼) to change setting.
4. Press (▲) or (▼) for about 2.5 seconds and release to save the data.

The allocation method of default address is fixed when module leaves the factory, it can set module address by button, the address range is 0x00~0x3E. It can also set the address allocation method to dynamic allocation by monitoring. At this time, the setting range of module group number is 0x00~0x07, it is displayed on the digital tube.

Modify the module address as follows: take 0x00 to 0x04 as an example to explain. Firstly, press (▼) to turn to page 3, the interface of 00 will appear, press (▲) or (▼) for about 2.5 seconds to release, the interface will blinking, then press (▲) for a short time continuously. Press (▲) or (▼) for about 2.5s to save after interface 04 appears.

Modify the module group number as follows: take 0x00 to 0x04 as an example to explain. Firstly, press (▼) to turn to page 4, the interface of 000 will appear, press (▲) or (▼) for about 2.5 seconds to release, the interface will blinking, then press (▲) for a short time continuously. Press (▲) or (▼) for about 2.5s to save after interface 004 appears.

When module appears faults, it can adjust to the interface of fault code by button. The module alarm information is displayed on the LED digital tube in the form of fault code, the fault codes are shown in table 2-3.

Fault code	Meaning
E01	Output undervoltage
E02	Overtemperature (Including environment over temperature of ambient temperature and internal over temperature of module because of air duct blocked)
E03	AC over/under voltage, AC no-full-phase
E05	Output short circuit
E06	Output overvoltage
E07	Address confliction
E08	Fan fault
E09	Current sharing alarm

2) The connector Definitions

The rear end of the charging module has AC input connector and DC output connector. As show in figure 2-4.

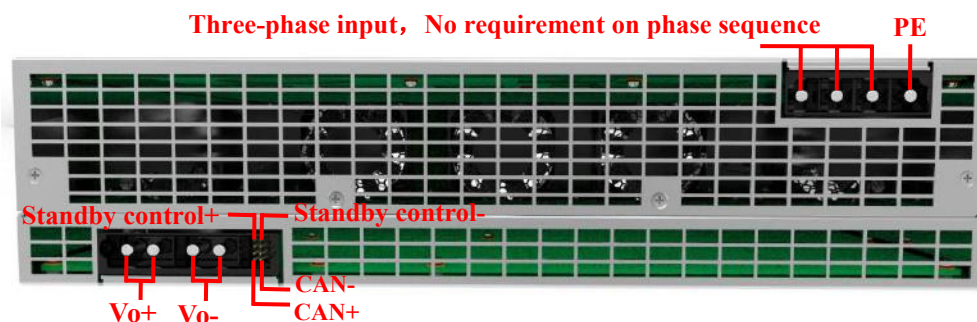

Figure 2-4 Schematic Diagram for Definition of Three-phase AC Input/DC Output Port

3) Label

Label is attached to the top cover of charging module, see figure 2-5.

Charging Module	
Model:	MXR100040
AC input:	285-475V/75A
DC output:	100-1000V/0-133.3A
Power:	40kW
Constant power voltage range:	300-1000V
Made in China	

2.2 Dimensions

2.2.1 The dimension of MXR100040 is shown in figure 2-6.

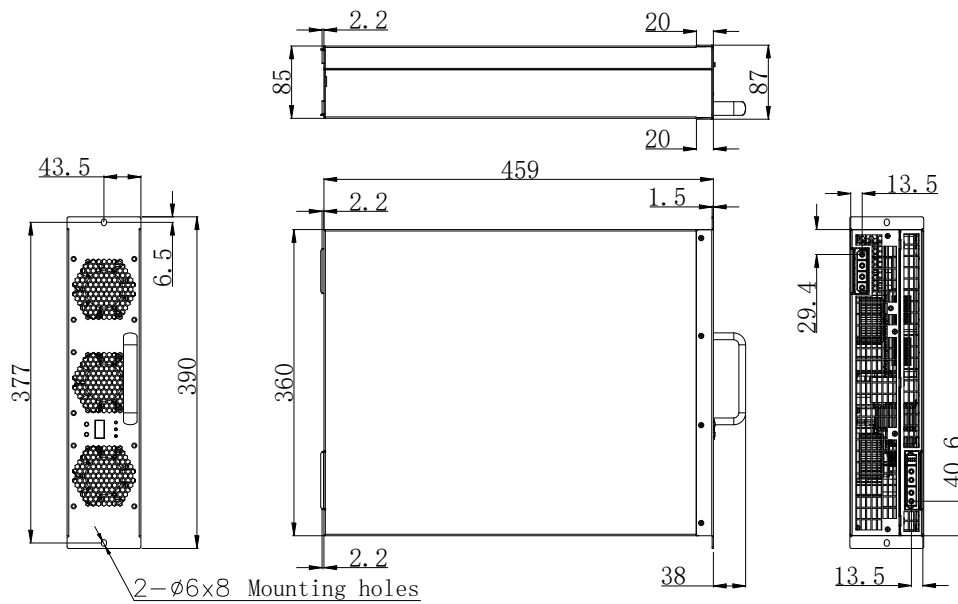

Figure 2-6 Module Dimensions (mm)

2.2.2 MXR100040 module system connector installation standard:

1) System connector (input cable connector, output cable connector) are installed on the connector installation panel, see Figure 2-7

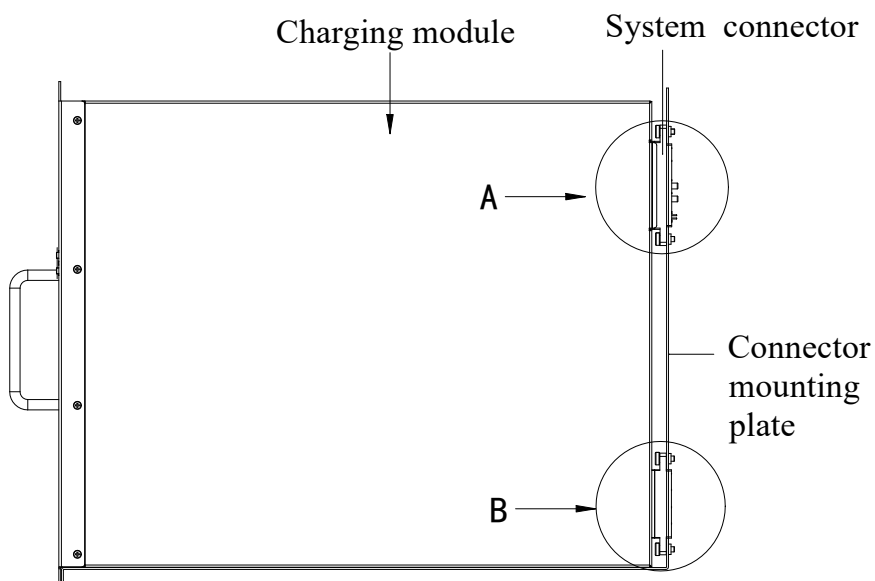

Fig. 2-7 Mounting of system connector

2) After the module is mounted on the pile, it is required that module connector and system connector are tightly connected, no gaps allowed. Ensure module connector and system connector are connected reliably, see Figure 2-8.

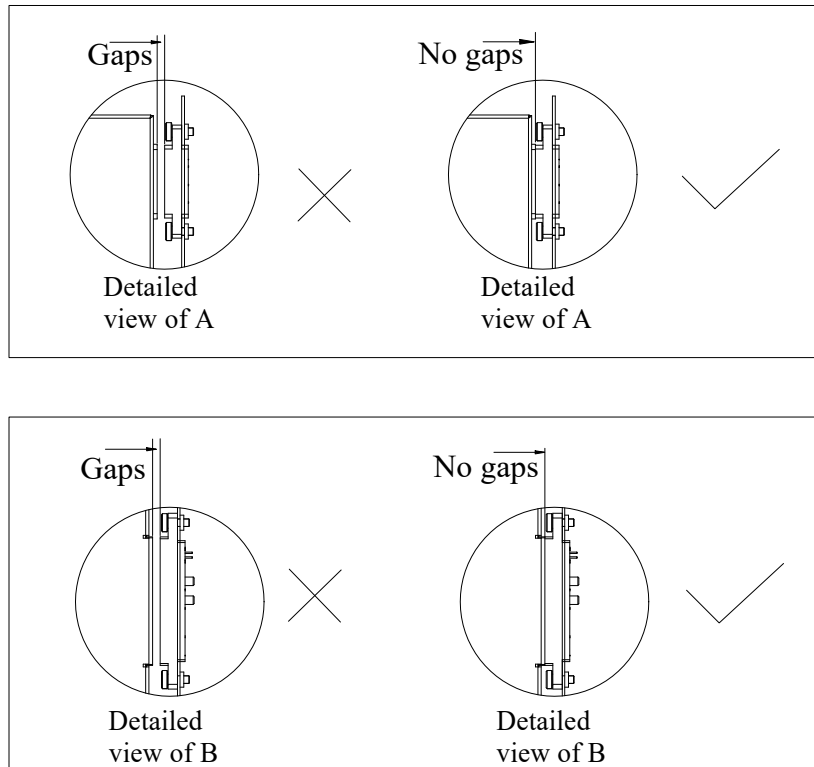

Figure 2-8 Module connector and System connector Installation

2.3 Installation

Installation steps of charging module are as follows,

1. Grab handle of charging module with one hand, and hold charging module with the other. Insert charging module into the corresponding position of the cabinet.
2. Slowly push the charging module into slot completely.
3. Tighten fixing screws on the charging module panel and fix it on the cabinet.
4. Charging modules should installed into the cabinet from left to right.

2.4 Use

After the charging modules are installed in the system cabinet, the system can run upon power-on.

Operating environment

1. Overvoltage/installation category: overvoltage category II.
2. Pollution grade: pollution grade III.
3. Altitude: No derating if it is ≤ 2000 m. The working temperature decreases by 1°C for every 100 m rise when the altitude is >2000 m.
4. AC input distribution system: TN or TT system.
5. System exhaust air volume and fan type selection requirements:

(1) There are two methods to calculate the exhaust air volume of system

Method 1: According to the total loss of system

According to the thermal formula, $V=Q/(C_P*\rho*\Delta T)$, the system exhaust air volume V (m^3/s) can be calculated, where C_P is the specific heat of air at the current temperature ($\text{kJ}/(\text{kg}*\text{K})$), ρ is

air density (kg/m^3) at the current temperature, and the current temperature is the average temperature of the inlet air and the outlet air, ΔT is the temperature difference between the inlet and the outlet of the system (18°C is generally selected for outdoor cabinet), Q is the total loss of the system (unit: kw) (Q value shall also be added with solar radiation in the strong sunlight regions).

Method 2: According to the exhaust air volume of the module

If the max exhaust air volume of a single module: $v=190$ CFM ($0.897 \text{ m}^3/\text{s}$), then the exhaust air volume of system $V=n*v$, n is the number of the system modules.

(2) The Selection of System Fan

The selection of system fan is decided by the system exhaust air volume V , and the main parameters are the maximum exhaust air volume and wind pressure of the fan, the maximum exhaust air volume of the system fan is equal to $1.5 \sim 2$ times of the system exhaust air volume ($1.5 \sim 2$) * v) when the pressure of wind is equal to the system impedance. If the pressure of wind is high and the system impedance is small, it can be close to 1.5 times; if the pressure of wind is low and the system impedance is large, it can be 2 times or even more than 2 times.

In general, the pressure of wind is not less than 200Pa , which can be calculated as 2 times.

6. Module usage suggestion

When the charging module is used in the charging pile system, ΔT : The difference in temperature of air intake and air outtake of the module (including the air intake and air outtake of charging pile) should not exceed 30°C , the specific test points are shown in the following figure:

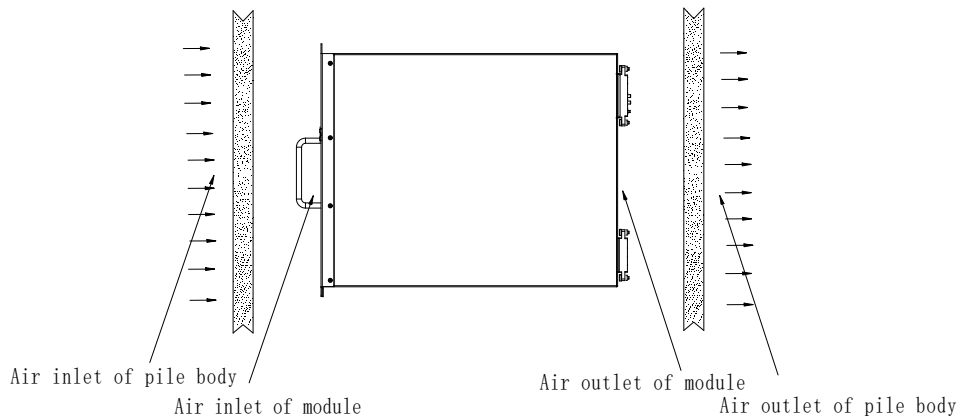

3 Maintenance Guide

3.1 Troubleshooting

Chart 3-1 Troubleshooting Instructions (Standard Protocol)

Indicator	Description	Analysis	Solution.
Run Indicator (Green) off	Module communication fail	No input voltage	Ensure there is input voltage .
		Charging module is not fully plugged in the slot	Re-plug the module.
Alarm Indicator (Yellow) Steady On	Module overheat Fault code:E02	Fan blocked	Remove the object that prevents the fan from.
		Air duct blocked	Remove the object that blocks air duct or clear dust.
	Module current imbalance Fault code:E09	The difference between the module current and average current is too large	Check charging module communication, check communication cable connection; If the communication is good and alarm persists, replace charging module.
	PFC voltage abnormal	PFC output over/under voltage protection	Swap charging module with alarm with a normal charging module, if alarm persists, replace charging module.
	AC over/under voltage Fault code:E03	AC input voltage is not in the normal range	Ensure AC input voltage is in the normal range
	Module communication fail	Module communication fail	Check communication cable connection
	Module short circuit Fault code:E05	Module positive and negative pole short circuit	Power off the charging module, check whether the positive and negative poles on the output circuit are short circuited, and reboot after confirming that there is no short circuit. If alarm persists, replace charging module.

Fault Indicator (Red) Steady On	Module overvoltage Fault code:E06	Module output voltage exceeds the set output overvoltage value	Power off the charging module, check whether the module output voltage has been changed, and check that the module output voltage is less than the set module output overvoltage value. And then, reboot after pulling out the charging module, if alarm persists, replace charging module.
	Address confliction Fault code:E07	Address confliction	Check if module operates in DIP switch mode. If so, check if there is a confliction in DIP switch address.
	Fan fault	Fan fault	Replace the fan.

3.2 Replace Charging Module

In case of module fault, please follow the steps below to replace charging module,

1. Surface temperature of charging module maybe high, be careful when pulling a module out;
2. Check whether the appearance of new charging module is intact; set DIP switch address the same as the replaced module;
3. Disconnect the ac input circuit breaker of the fault charging module, loosen the fixing screws on the panel;
4. Grab the handle of the failed charge module, pull it out of the cabinet slowly;
5. Slowly push the new charging module into the cabinet;
6. Tighten the fixing screws on the panel;
7. Close the charging module ac input circuit breaker;
8. Check whether the monitor module can identify the newly replaced charging module, and check current sharing between newly replaced charging module and. If all items are normal, it indicates that newly replaced module is in normal operation.

Appendix I Identification Chart of Toxic and Harmful Substance

Component	Toxic or harmful substances or elements					
	Lead	Mercury	Cadmium	Hexavalent Chromium	Polybrominated Biphenyl	Polybrominated Diphenyl Ethers
	Pb	Hg	Cd	Cr6+	PBB	PBDE
Fan	X	O	O	O	O	O
Manufactured board	X	O	O	O	O	O
Metals	X	O	O	O	O	O
<p>○ : indicates that the content of the toxic and hazardous substance in all homogeneous materials of the part is below the limit requirement specified in SJ/T 11363—2006.</p> <p>×: indicates that the content of the toxic or hazardous substance contained in at least one of the homogeneous materials of the part exceeds the limit requirement of SJ/T 11363—2006.</p>						
<p>Toxic and hazardous substances contained in the following components and applications are limited to the current technical level and cannot be replaced reliably or there is no mature technical solution:</p> <ol style="list-style-type: none"> 1. The solder contains lead; 2. Lead in copper; 3. High temperature solders contain lead. 						
<p>Remarks about environmental protection period of use: The environmental protection period of use of the this product (marked on the product) refers to the period, from the production date, under normal conditions of use, complying with the safety precautions, during which product contained toxic and harmful substances or elements will not have serious impact on the environment, personal and property.</p>						
<p>Scope of application: MXR series charging module.</p>						